

DL - DL W/C

SUBMERSIBLE SEWAGE PUMP (DL) WITH CUTTER (DL W/C)



SPECIFICATIONS

PUMP		
Liquid	Type of liquid	Sewage
	Temperature	0-40°C
Synchronous Speed		~1450 min ⁻¹
Construction	Mechanical Seal	Double mechanical seal
	Impeller	Non-Clog single-channel, double-channel Vitex open
	Bearings	Pre-lubricated bearings
Material	Casing	Cast iron
	Impeller	Cast iron
	Suction Cover	Cast iron
	Shaft	403 Stainless Steel
	Motor Frame	Cast iron
	Mechanical Seal	Impeller side Motor side
MOTOR		
Type	Air filled dry submersible three phase	
N° of poles	4 poles	
Insulation Class	Class F	
Starting method	DOL (up to 7,5kW) Star-Delta (11-45 kW)	
Degree protection	IP68	
ACCESSORIES		
Option	Quick discharge connector (QDC)	

The pump is equipped with a discharge elbow.

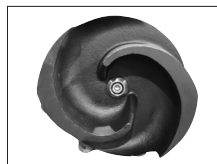

DL IMPELLER



DL W/C IMPELLER



DLC AND DLB IMPELLER

SOLIDS HANDLINGS										
Model		DL	DL, DLC	DLC	DL, DLB	DL	DL	DL	DL	DL
Output diameter	[mm]	65	80	100(80)	100	150	200	250	300	150, 200, 250, 300
Power	[kW]	1,5	1,5÷7,5	5,5÷7,5	3,7÷18,5	5,5÷22	5,5÷22	7,5÷22	7,5÷22	30÷45
Max. Diameter of Solids	[mm]	35	50	50	60	70	76	82	90	76
Max. Length of Fibers	[mm]	195	240	240	300	400	500	550	600	500

PUMP IDENTIFICATION CODE

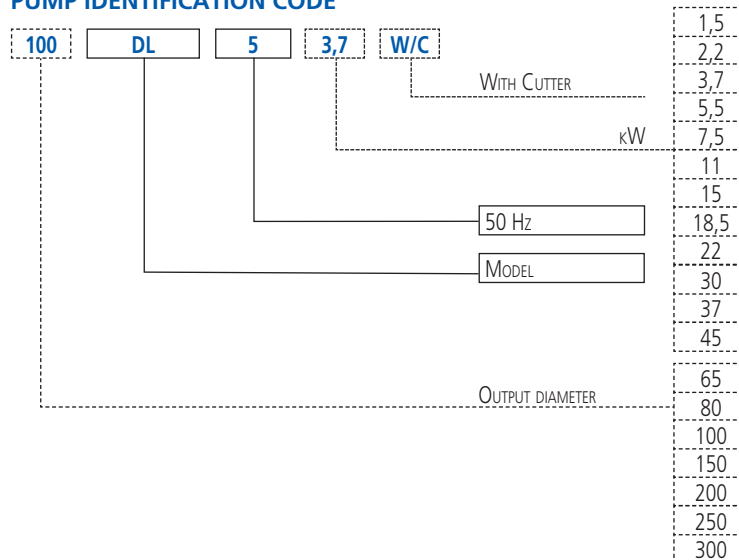

Model DL - DL W/C (WITH CUTTER)

Features:

- Non-Clog single-channel, double-channel Vitex open impeller prevents clogging by fibrous matter
- Range of models from 65 to 300 mm discharge size and power up to 45 kW (DL)

Applications:

- Ideal for waste water applications containing soft or fibrous solids
- Industrial waste water drainage



DL - DL W/C

SUBMERSIBLE SEWAGE PUMP (DL) WITH CUTTER (DL W/C)

PERFORMANCE CHART

65-80DL

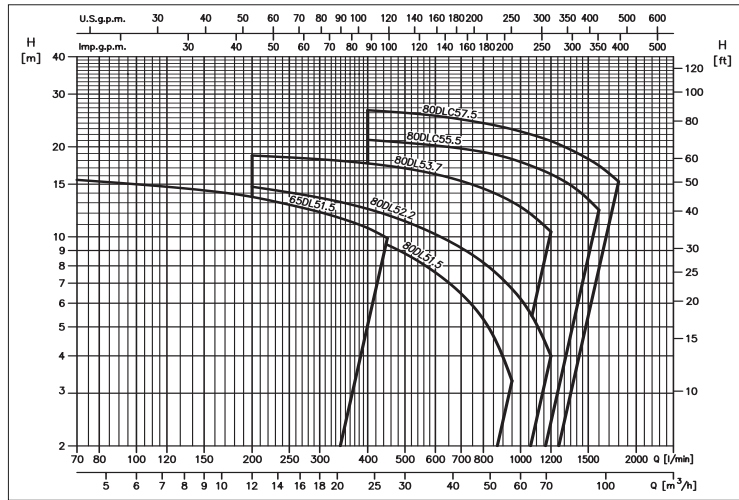

200DL

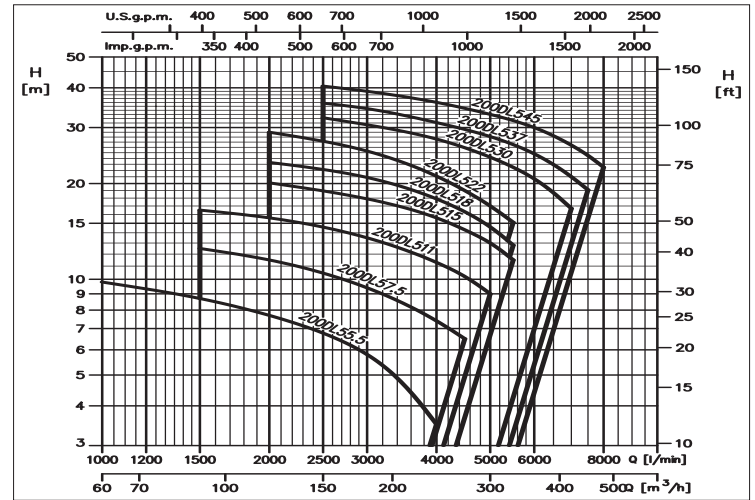

100DL

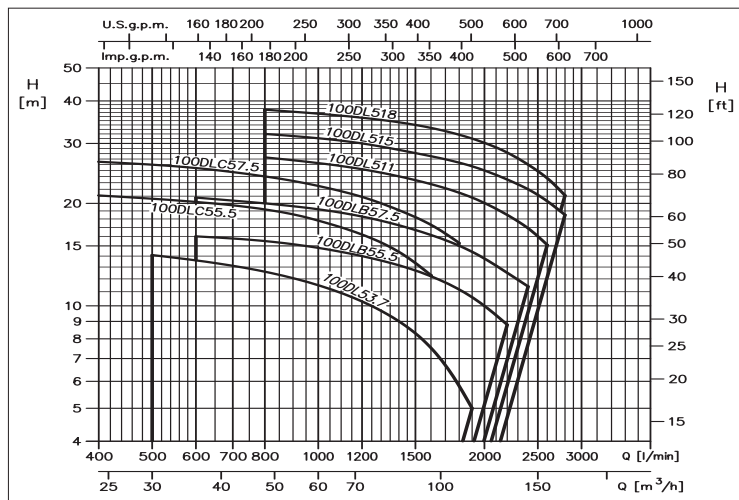

250DL

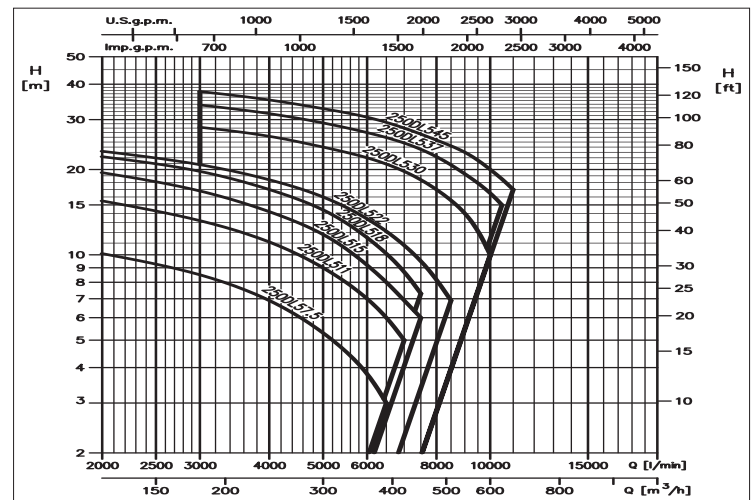

150DL

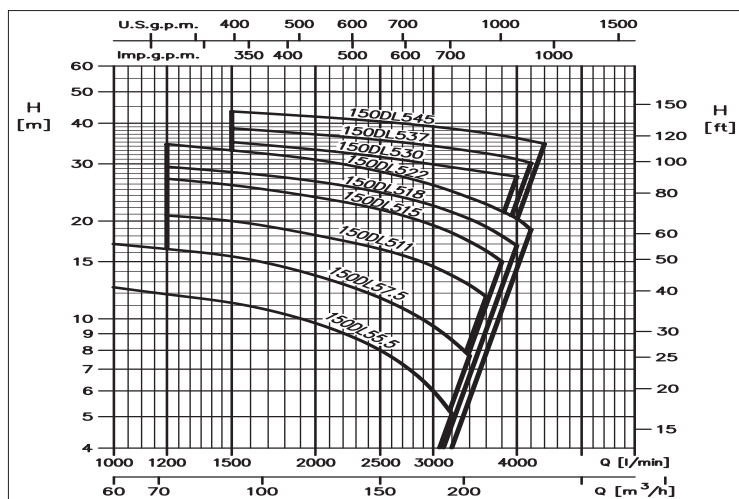

300DL

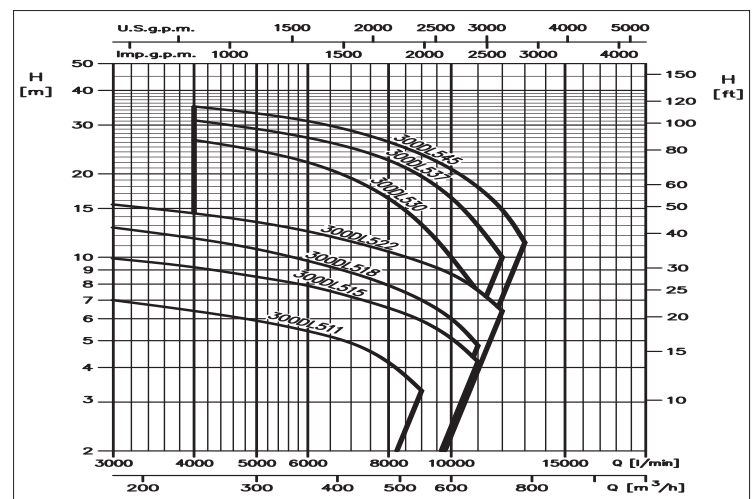

DL - DL W/C

SUBMERSIBLE SEWAGE PUMP (DL) WITH CUTTER (DL W/C)

PERFORMANCE CHART DL W/C (WITH CUTTER)

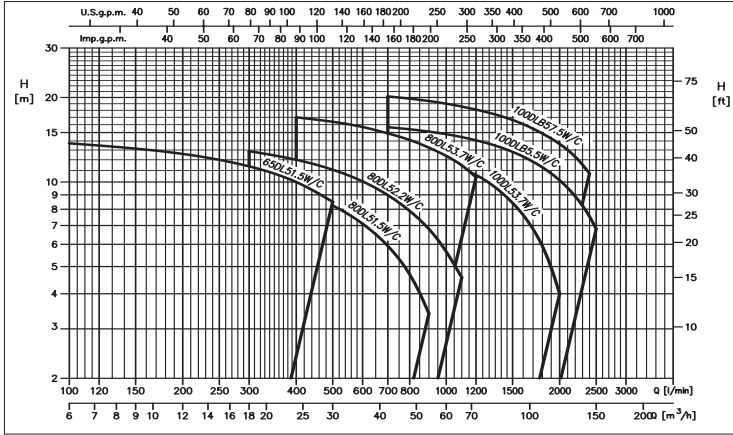

PERFORMANCES TABLE 65-80DL

Model	P ₂		Q = Capacity													
	[kW]	[HP]	l/min 70	150	200	400	450	600	800	950	1000	1200	1400	1600	1800	
			H = Head [m]													
			m ³ /h 4	9	12	24	27	36	48	57	60	72	84	96	108	
65DL51.5	1,5	2	15,5	14,3	13,6	10,7	9,9	-	-	-	-	-	-	-	-	
80DL51.5	1,5	2	-	-	12,2	10,0	9,4	7,6	5,3	3,3	-	-	-	-	-	
80DL52.2	2,2	3	-	-	14,7	12,4	11,8	10,2	8,2	6,7	6,2	4,0	-	-	-	
80DL53.7	3,7	5	-	-	18,7	17,6	17,3	16,2	14,5	13,1	12,6	10,4	-	-	-	
80DLC55.5	5,5	7,5	-	-	-	21,1	20,9	20,2	19,2	18,2	17,8	16,2	14,4	12,3	-	
80DLC57.5	7,5	10	-	-	-	26,5	26,3	25,4	24,0	22,9	22,5	20,9	19,1	17,3	15,3	

PERFORMANCES TABLE 100DL

Model	P ₂		Q = Capacity													
	[kW]	[HP]	l/min 400	500	600	800	1200	1500	1600	1800	1900	2200	2400	2600	2800	
			H = Head [m]													
			m ³ /h 24	30	36	48	72	90	96	108	114	132	144	156	168	
100DLC55.5	5,5	7,5	21,1	20,7	20,2	19,2	16,2	13,3	12,3	-	-	-	-	-	-	
100DLC57.5	7,5	10	26,5	25,9	25,4	24,0	20,9	18,3	17,3	15,3	-	-	-	-	-	
100DL53.7	3,7	5	-	14,1	13,6	12,6	10,3	8,3	7,5	5,9	5,0	-	-	-	-	
100DLB55.5	5,5	7,5	-	-	16,0	15,5	14,0	12,7	12,2	11,1	10,6	8,8	-	-	-	
100DLB57.5	7,5	10	-	-	20,8	20,0	18,3	16,7	16,1	15,1	15,0	12,5	11,4	-	-	
100DL511	11	15	-	-	-	27,3	25,2	23,4	22,8	21,5	20,8	18,5	16,9	15,1	-	
100DL515	15	20	-	-	-	32,0	30,0	28,1	27,6	26,4	25,7	23,5	22,0	20,3	18,5	
100DL518.5	18,5	25	-	-	-	37,7	35,7	34,0	33,4	31,9	31,0	28,2	26,0	23,7	21,1	

PERFORMANCES TABLE 150DL

Model	P ₂		Q = Capacity													
	[kW]	[HP]	l/min 1000	1200	1500	2000	2500	3000	3200	3400	3500	3600	3800	4000	4200	4400
			H = Head [m]													
			m ³ /h 60	72	90	120	150	180	192	204	210	216	228	240	252	264
150DL55.5	5,5	7,5	12,5	11,9	11,2	9,7	8,0	6,0	5,1	-	-	-	-	-	-	-
150DL57.5	7,5	10	17,0	16,4	15,2	13,6	11,6	9,5	8,6	7,7	-	-	-	-	-	-
150DL511	11	15	-	20,8	20,0	18,1	16,4	14,5	13,6	12,7	12,2	11,7	-	-	-	-
150DL515	15	20	-	27,0	25,8	23,7	21,7	19,4	18,4	17,3	16,8	16,2	15,0	-	-	-
150DL518.5	18,5	25	-	29,4	28,3	26,5	24,5	22,3	21,3	20,3	19,8	19,2	18,0	16,8	-	-
150DL522	22	30	-	34,5	33,0	30,9	28,4	25,8	24,7	23,6	23,0	22,4	21,2	20,5	18,8	-
150DL530	30	40	-	-	35,0	33,2	31,5	29,9	29,3	28,8	28,5	28,3	27,8	27,4	-	-
150DL537	37	50	-	-	38,6	37,0	35,5	34,1	33,5	32,9	32,6	32,3	31,7	31,0	30,2	-
150DL545	45	60	-	-	43,5	42,0	40,5	39,1	38,5	37,9	37,6	37,3	36,7	36,0	35,3	34,6

DL - DL W/C

SUBMERSIBLE SEWAGE PUMP (DL) WITH CUTTER (DL W/C)

PERFORMANCES TABLE 200DL

Model	P ₂		Q = Capacity												
	[kW]	[HP]	V _{min} 1000	1500	2000	2500	3000	4000	4500	5000	5500	6000	7000	7500	8000
			m ³ /h 60	90	120	150	180	240	270	300	330	360	420	450	480
H = Head [m]															
200DL55.5	5,5	7,5	9,8	8,7	7,7	6,8	5,8	3,5	-	-	-	-	-	-	-
200DL57.5	7,5	10	-	12,5	11,5	10,5	9,4	7,4	6,5	-	-	-	-	-	-
200DL511	11	15	-	16,5	15,6	14,6	13,5	11,3	10,2	9,0	-	-	-	-	-
200DL515	15	20	-	-	20,1	19,0	17,9	15,6	14,3	13,0	11,5	-	-	-	-
200DL518.5	18,5	25	-	-	23,3	22,2	20,9	17,9	16,3	14,6	12,8	-	-	-	-
200DL522	22	30	-	-	29,0	27,2	25,3	21,1	19,0	17,0	15,1	-	-	-	-
200DL530	30	40	-	-	-	32,2	30,6	27,6	25,9	24,2	22,5	20,7	16,7	-	-
200DL537	37	50	-	-	-	35,8	34,4	31,1	29,6	28,1	26,5	24,8	21,0	19,1	-
200DL545	45	60	-	-	-	40,5	39,0	36,0	34,5	33,0	31,5	30,0	26,4	24,5	22,5

PERFORMANCES TABLE 250DL

Model	P ₂		Q = Capacity													
	[kW]	[HP]	V _{min} 2000	3000	4000	5000	6000	6500	7000	7500	8000	8500	9000	10000	10500	11000
			m ³ /h 120	180	240	300	360	390	420	450	480	510	540	600	630	660
H = Head [m]																
250DL57.5	7,5	10	10,1	8,5	6,9	5,3	3,8	3,0	-	-	-	-	-	-	-	-
250DL511	11	15	15,5	13,2	11,1	9,0	7,0	6,0	5,0	-	-	-	-	-	-	-
250DL515	15	20	19,5	16,8	14,2	11,8	9,2	8,0	6,9	6,0	-	-	-	-	-	-
250DL518.5	18,5	25	22,2	19,7	17,0	14,4	11,5	10,1	8,7	7,3	-	-	-	-	-	-
250DL522	22	30	23,2	20,8	18,4	16,0	13,4	12,1	10,8	9,5	8,2	6,9	-	-	-	-
250DL530	30	40	-	28,2	26,2	24,0	22,0	20,9	19,7	18,4	17,0	15,6	14,0	10,0	-	-
250DL537	37	50	-	33,8	31,5	29,2	27,0	25,9	24,8	23,5	22,2	20,8	19,3	16,5	15,0	-
250DL545	45	60	-	37,7	35,2	32,8	30,6	29,3	28,0	26,7	25,4	24,2	23,0	20,0	18,5	17,0

PERFORMANCES TABLE 300DL

Model	P ₂		Q = Capacity											
	[kW]	[HP]	V _{min} 3000	4000	5000	6000	7000	8000	9000	10000	11000	12000	13000	
			m ³ /h 180	240	300	360	420	480	540	600	660	720	780	
H = Head [m]														
300DL511	11	15	7,0	6,4	5,9	5,5	4,9	4,2	3,3	-	-	-	-	-
300DL515	15	20	9,9	9,2	8,5	8,0	7,2	6,6	5,9	5,1	4,2	-	-	-
300DL518.5	18,5	25	12,8	11,7	10,7	9,7	8,8	7,9	7,0	6,0	4,8	-	-	-
300DL522	22	30	15,5	14,4	13,4	12,4	11,4	10,5	9,6	8,7	7,6	6,4	-	-
300DL530	30	40	-	26,5	24,4	22,0	19,3	16,3	13,1	10,0	7,5	-	-	-
300DL537	37	50	-	31,2	29,2	27,0	24,8	22,4	19,6	16,4	13,0	10,0	-	-
300DL545	45	60	-	35,0	33,1	31,0	28,6	26,1	23,5	20,8	17,9	14,8	11,3	-

PERFORMANCES TABLE 65-80-100 DL W/C (WITH CUTTER)

Model	P ₂		Q = Capacity														
	[kW]	[HP]	V _{min} 100	250	300	400	500	700	900	1000	1100	1200	1400	1600	2000	2400	2500
			m ³ /h 6	15	18	24	30	42	54	60	66	72	84	96	120	144	150
H = Head [m]																	
65DL51.5W/C	1,5	2	13,7	12,0	11,4	10,0	8,5	-	-	-	-	-	-	-	-	-	-
80DL51.5W/C	1,5	2	-	10,7	10,3	9,3	8,2	5,9	3,4	-	-	-	-	-	-	-	-
80DL52.2W/C	2,2	3	-	-	12,9	12,0	11,1	9,0	6,8	5,7	4,6	-	-	-	-	-	-
80DL53.7W/C	3,7	5	-	-	-	17,0	16,4	14,9	13,4	12,6	11,6	10,4	-	-	-	-	-
100DL53.7W/C	3,7	5	-	-	-	-	14,1	13,1	12,2	11,7	11,2	10,6	9,2	7,6	4,0	-	-
100DLB55.5W/C	5,5	7,5	-	-	-	-	-	15,7	15,1	14,8	14,5	14,1	13,3	12,3	10,1	7,5	6,8
100DLB57.5W/C	7,5	10	-	-	-	-	-	20,2	19,4	19,0	18,6	18,1	17,2	16,1	13,7	10,7	-

DL - DL W/C

SUBMERSIBLE SEWAGE PUMP (DL) WITH CUTTER (DL W/C)

DIMENSIONS DL

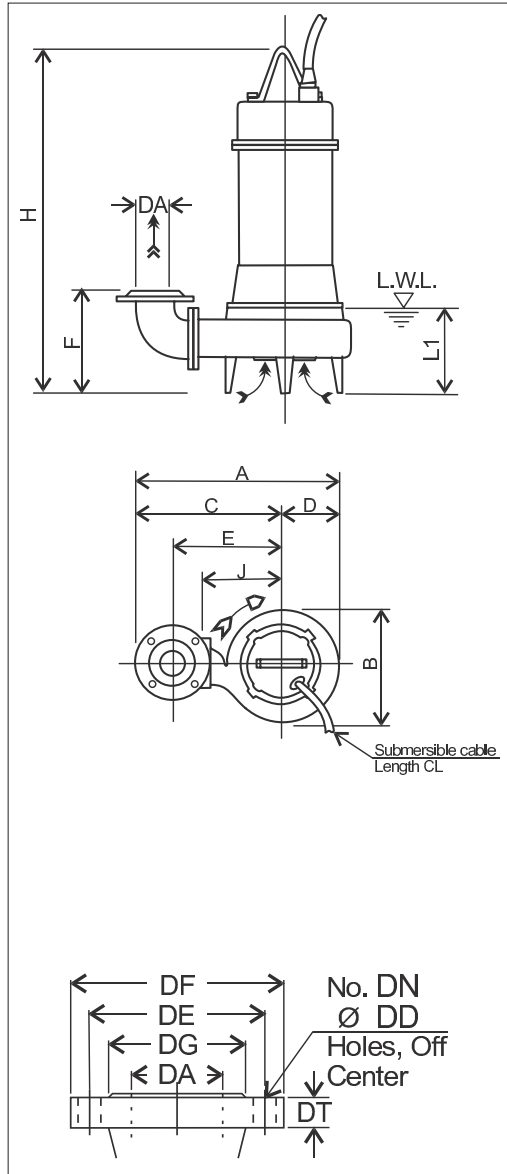

DIMENSIONS TABLE DL

DA	Model	[kW]	A	B	C	D	E	F	H	J	L1 (*)	E1	Weight [kg]	
65	65DL51.5	1.5	497	291	353	144	265	200	576	200	140		52	
80	80DL51.5	1.5	524	292	378	146	285		597	210	165		55	
	80DL52.2	2.2	542	308	388	154	295	220	654	220			67	
	80DL53.7	3.7	567	328	403	164	310		687	235	205		75	
	80DLC55.5	5.5	618	379	428	190	335	307	753	260			134	
	80DLC57.5	7.5	648	399	448	200	355	305	751	280			148	
100	100DL53.7	3.7	614	335	445	169	340	250	706	235	205	185	79	
	100DLB55.5	5.5	646	369	460	186	355	323	768	250			123	
	100DLC55.5	5.5	660	379	470	190	365	322	753	260			134	
	100DLB57.5	7.5	673	385	480	193	375	323	760	270			141	
	100DLC57.5	7.5	690	399	490	200	385	320	751	280			148	
	100DL511	11	701	402	500	201	395	323	859	290			180	
	100DL515	15		441	520	221	415	330	954	310			230	
	100DL518.5	18.5		441	520	221	415	330	958				285	
150	150DL55.5	5.5	750	398	550	200	410	381	799	280	245	10	146	
	150DL57.5	7.5	780	418	570	210	430		784	300				158
	150DL511	11		438	590	220	450	377	883	320				199
	150DL515	15	810						972					237
	150DL518.5	18.5	848	476	610	238	470	381	979	340				300
	150DL522	22	848	476	610	238	470	381	979	340				325
	150DL530	30		520	650	262	510	468	1284	360			486	350
	150DL537	37	912	520	650	262	510	468	1404	360			494	350
	150DL545	45		520	650	262	510	468		360				350
	200	200DL55.5	5.5	832	430	615	217	450	414	826			300	285
200DL57.5		7.5		453	635	228	470	410	809	320		176		
200DL511		11	863						908			212		
200DL515		15	896	479	655	241	490	411	995	340		260		
200DL518.5		18.5		512		257		415	1001			305		
200DL522		22	932									330		
200DL530		30			675		510		1284	360	486	350		
200DL537		37	937	520		262		483	1404		494	370		
200DL545		45										370		
250	250DL57.5	7.5	969	525	700	269	500	622	904	370	400	10	260	
	250DL511	11	993	541	720	273	520	634	1000	390				320
	250DL515	15							1086					380
	250DL518.5	18.5	1007	549	730	277	530	646	1089	400				420
	250DL522	22												440
	250DL530	30							1336				538	458
	250DL537	37	1125	660	790	335	590	706	1475	460			565	522
250DL545	45										540			
300	300DL511	11	1100	588	798	302	575	671	1050	420	450	10	365	
	300DL515	15												395
	300DL518.5	18.5	1135	618	818	317	595	668	1131	440				440
	300DL522	22												465
	300DL530	30							1336				538	458
	300DL537	37	1172	660	838	335	615	726	1475	460			565	522
	300DL545	45												540

(*) - L.W.L (Low Water Level)

DL - DL W/C

SUBMERSIBLE SEWAGE PUMP (DL) WITH CUTTER (DL W/C)

DIMENSIONS DL W/C (with cutter)

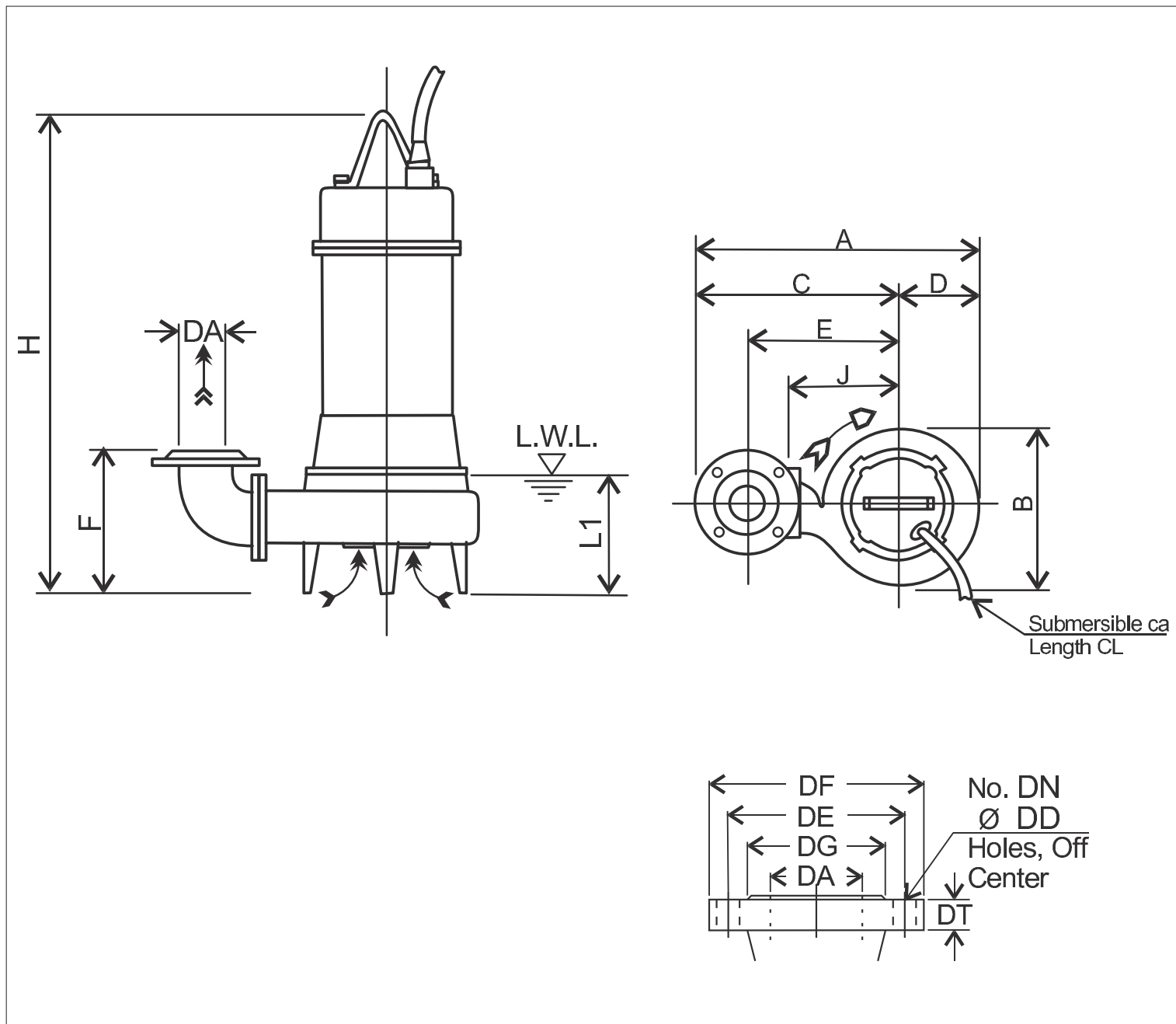

DIMENSIONS TABLE DL W/C (with cutter)

DA	Model	[kW]	A	B	C	D	E	F	H	J	L1 (*)	CL [m]	Weight [kg]
65	65DL51.5W/C	1.5	497	291	353	144	265	200	576	200	140	10	52
80	80DL51.5W/C	1.5	524	292	378	146	285	220	597	210	165		55
	80DL52.2W/C	2.2	542	308	388	154	295		654	220			67
	80DL53.7W/C	3.7	567	328	403	164	310		687	235			75
100	100DL53.7W/C	3.7	614	335	445	169	340	250	706	205	185	79	
	100DLB55.5W/C	5.5	646	369	460	186	355	323	768		250	123	
	100DLB57.5W/C	7.5	673	385	480	193	375	760	270		141		

(*) - L.W.L (Low Water Level)