

## FEATURE

- Design for civil engineering, light weight for easy portability, double outer casing water cooling motor make it possible to run the pump to low water level.
- Best waterproof structure, automatic reset motor protector and double mechanical seals made of silicon carbide. Durable and leakproof.
- Compact, strong design and easy operation in any place.
- Impeller made of high chrome alloy (HCR) steel with a hardness of 55~60 Rc. Harden and abrasion resistant.
- Equipped with a cast iron (FCD) agitator to create powerful stirring and pumping action for slurry.

## APPLICATIONS

- Civil engineering, dewatering for tunnel engineering also for manhole sewer.
- Dewatering fluid containing solid sediment.
- Mobile use for contractors, installers and industry.



AG-32



80AGH25.5  
100AGN25.5/7.5

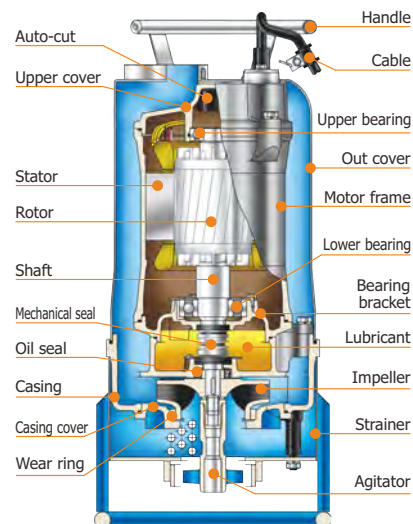

## PERFORMANCE CURVES

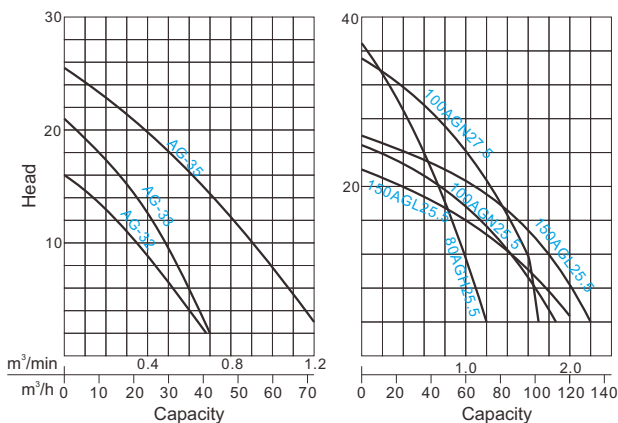

## SPECIFICATIONS

Item		Description			
Power		2~5HP	7.5~10HP		
Liquid temp.		0~40°C(32~104°F)			
Applications		Dewatering fluid containing solid sediment			
Max depth		30m			
Pump sect.	Structure	Impeller	Semi-open	Semi-open	Enclosed channel
		M. seal	Double M. seals		
		Bearing	Ball type		
	Material	Out cover	SUS304		
		Upper cover	FC-200		
		Casing	FC-200		
Motor sect.	Material	Impeller	HCR		
		M. seal	Lower: Sic/Sic · Upper: CA/CE		
		Motor	Dry motor		
	Material	Insulation	F Class ( 2~3HP : B Class )		
		Frequency	50Hz		
		Protector	Auto-cut		
Material	Frame	SUS304	FC-200		
	Main shaft	SUS420J2 ( 2~3HP : SUS403 )			
	Cable	VCT or H07RN-F or SJOW/SOW			

※Pumps can be customized to fit specifications.

## PERFORMANCE SPEC.

Model	Power HP(kW)	Discharge Inch(mm)	Phase	Start Method	Head m	Method		Weight kg 1 /3	Solid Passage mm	Dimension (mm)		
						m <sup>3</sup> /min	m <sup>3</sup> /h			Length	Width	Height
AG-32	2(1.5)	3"(80)	3	Capacitor	9	0.4	24	45	11	-	255	682
				Direct								38
AG-33	3(2.2)	3"(80)	3	Capacitor	13	0.4	24	45	11	-	255	682
				Direct								40
AG-35	5(3.7)	3"(80)	3	Direct	18	0.5	30	46	11	-	255	628
80AGH25.5	7.5(5.5)	3"(80)	3	Direct	27	0.5	30	64	10	-	286	734
100AGN25.5	7.5(5.5)	4"(100)	3	Direct	18	1.0	60	72	10	-	286	734
100AGN27.5	10(7.5)	4"(100)	3	Direct	24	1.0	60	74	10	-	286	734
150AGL25.5	7.5(5.5)	6"(150)	3	Direct	11	1.5	90	75	10	-	286	796
150AGL27.5	10(7.5)	6"(150)	3	Direct	16	1.5	90	76	10	-	286	796

Note : Weight W/O Cable